

# MODEL 76 RUBBER WIPER BLADE CONVEYOR BELT CLEANER AND MODEL 74 PLOW TYPE CONVEYOR BELT CLEANER

## MODEL 76 RUBBER WIPER BLADE TYPE CONVEYOR BELT CLEANER

- Eliminates wear by removing abrasive materials
- Saves clean-up expenses, cuts maintenance costs
- Available from stock for belts 12" thru 72" • Can be left in contact with belt even when belt is reversed
- Built-in safety feature: rubber blade can only be returned to extent springs are compressed. Features mechanically adjustable safety stop
- Economical-low initial cost, easy to install and no moving parts
- Highest quality 1"x6" rubber wiper material furnished as standard. Blade is reversible for double wear.

Inexpensive, easy to install, effective and virtually maintenance free. You cannot afford to be without our Model 76 or Model 74 cleaning you conveyor belt.

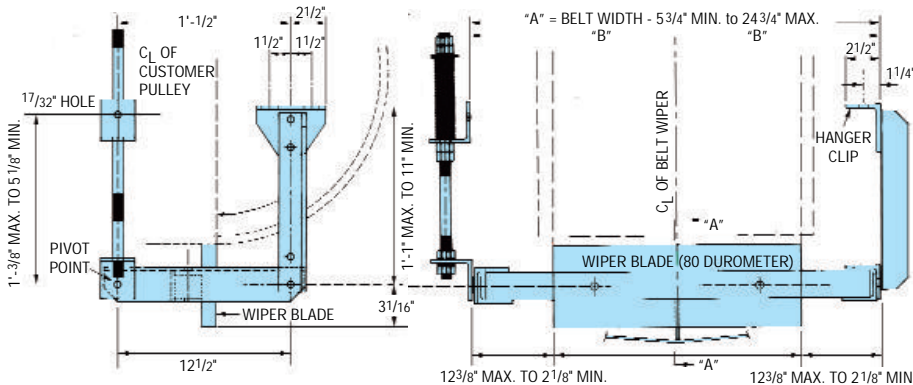

**APPLICATION AND INSTALLATION INSTRUCTIONS:**

**GENERAL:** The Model 76 cleaner is designed for easy installation and servicing. Belt size determines size of cleaner to be ordered. The support bar is long enough to adjust to fit any normal width conveyor frame. Hangers offer ample vertical height adjustment. On reversing conveyors we suggest the use of two Model 76 cleaners. One to be located under each end pulley.

**KEEP THESE POINTS IN MIND WHEN INSTALLING:**

1. Standard unit adjusts to conveyor frame width as follows: MINIMUM width "A" is 5 3/4" wider than specified belt size. MAXIMUM width "A" is 24 3/4" wider than specified belt size.
2. Make sure discharge chute is large enough to catch droppings.
3. File down any extreme projections on metal splice.
4. For best results position cleaners directly on head pulley.

**ORDERING INFORMATION**

BELT WIDTH	NET WT. LBS.	PRICE
12"	40	\$181.00
16"	42	197.00
18"	43	206.00
20"	44	213.00
24"	47	231.00
30"	50	265.00
36"	54	290.00
42"	57	315.00
48"	61	344.00
54"	64	368.00
60"	68	395.00
72"	75	447.00

Complete Cleaner has 1"x6" D-80 Rubber Blade. Stainless steel construction available upon quotation.

**REPLACEMENT BLADES**

BELT WIDTH	NET WT. LBS.	PRICE
12"	3.2	\$20.07
16"	4.3	26.75
18"	4.8	30.11
20"	5.3	33.45
24"	6.4	40.14
30"	8.0	50.18
36"	9.6	60.21
42"	11.2	70.25
48"	12.8	80.27
54"	14.4	90.31
60"	16.0	100.34
72"	19.2	120.41

Made from our own 1"x6" D-80 solid Rubber. Can be used on any rubber wiper type belt cleaner. Blades are cut to length but not drilled or slotted.

## "D-80" CONVEYOR BELT WIPER RUBBER

**ABSOLUTELY THE FINEST BELT CLEANER MATERIAL AVAILABLE**  
(used as standard wiper material on our model 74 and 76 cleaners)

Our D-80 belt wiper rubber is an 80 durometr solid rubber compounded especially for belt cleaning applications. It has the proper stiffness, and probably just as important, it is highly abrasive resistant. We guarantee it to improve the cleaning effectiveness of your belt cleaners.

Now at prices competitive with ineffective substitutes such as skirtboard rubber and chute lining. We will cut into desired blade lengths at no extra charge.

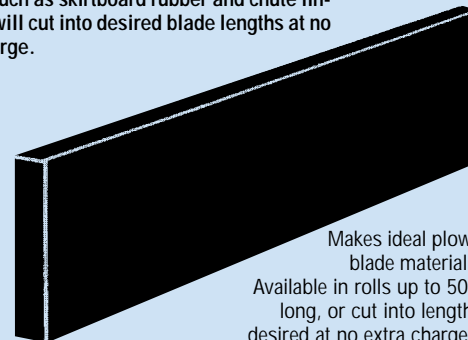

•Straight, smooth edge. •80 Durometer "D-80" gives proper stiffness for belt cleaning • Available in 4 sizes from stock.

Makes ideal plow blade material. Available in rolls up to 50' long, or cut into length desired at no extra charge.

There is no extra charge to cut your order into individual lengths if desired. All our rubber is sold on a per foot basis with no extra charge for cutting. We do have a minimum order quantity of \$15.00 on D-80 rubber material.

PART NO.	GAUGE	WIDTH	NET LBS. PER FT.	PRICE PER LINEAL FT.
0124	1/2"	4"	1.0 lbs.	\$ 7.29
0126	1/2"	6"	1.6 lbs.	10.22
1006	1"	6"	3.2 lbs.	20.07
1009	1"	9"	4.7 lbs.	31.70



**MATERIAL CONTROL, INC.**  
197 POPLAR PL., UNIT 3  
P.O. BOX 308  
NORTH AURORA, IL 60542-0308

©Copyright 1990 Material Control, Inc.  
www.materialcontrolinc.com  
email: sales@materialcontrolinc.com

800-926-0376 • 630-892-4274 • FAX 630-892-4931  
SUBJECT TO CHANGE WITHOUT NOTICE • TERMS: NET 30 DAYS  
F.O.B. FACTORY • TAX NOT INCLUDED  
PRICES EFFECTIVE 2/1/06