

# FLOW SWITCH

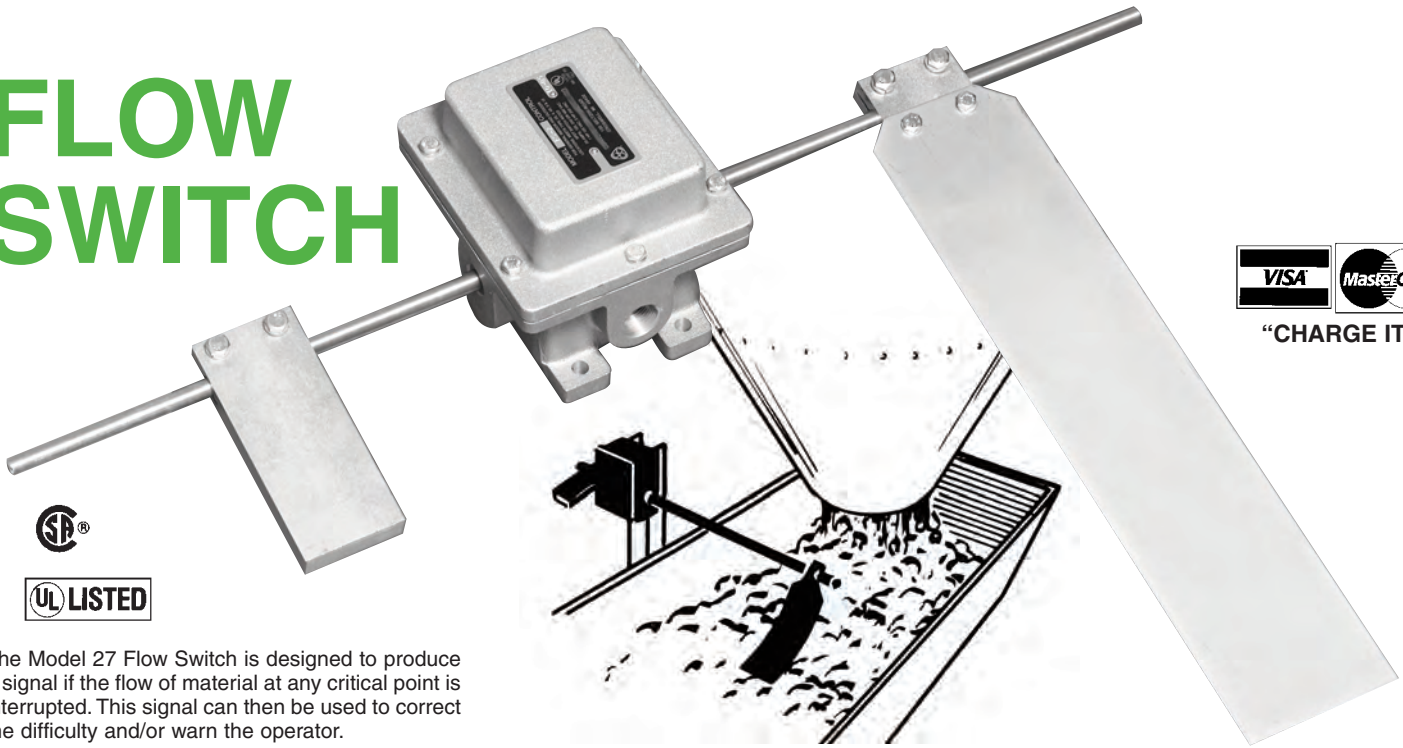

“CHARGE IT”



The Model 27 Flow Switch is designed to produce a signal if the flow of material at any critical point is interrupted. This signal can then be used to correct the difficulty and/or warn the operator.

Several switches can be used, each one placed at critical points along the conveying system. A continuous flow of material past the switch holds the paddle-shaft-counterweight assembly out of the actuated position. If flow stops, the paddle is allowed to pivot and actuate the switch. When it occurs a signal is generated to start or stop supporting machinery, or to activate visual or audible alarm systems.

Model 27 is also fully adjustable. The paddle and counterweight assemblies can be positioned at various points along the shaft and rotated to any angular position. The shaft itself will adjust laterally. Inside, the actuating cams can be rotated so that switch actuation will occur at predetermined points.

This versatile switch can be mounted on all types of conveyors and feeders; in discharge openings of bins, bunkers, or hoppers; in angled and vertical chutes; or in discharge chutes of any configuration. It is available with either a aluminum or epoxy coated housing, and in standard or explosion proof models. The paddle and shaft are both of stainless steel.

## MODELS AVAILABLE

MODEL	DESCRIPTION	PRICE
27-1	One sp/dt micro switch	SEE PRICE FOR SHEET FOR PRICING
27-2	Two sp/dt micro switches	
27-1X	Explosion proof with one sp/dt micro switch	
27-2X	Explosion proof with two sp/dt micro switches	



PRICES SUBJECT TO CHANGE WITHOUT NOTICE • TAX NOT INCLUDED  
• TERMS: NET 30 DAYS  
• F.O.B. FACTORY

## MATERIAL CONTROL, INC.

197 POPLAR PL. • UNIT 3  
P.O. BOX 308

NORTH AURORA, IL. 60542-0308

800-926-0376 • 630-892-4274

FAX 630-892-4931

www.materialcontrolinc.com

email: sales@materialcontrolinc.com

## TECHNICAL INFORMATION

- Housing — Aluminum, Epoxy Coated (optional) • Conduit opening — one, 3/4"
- Shaft and Paddle — Stainless Steel • Switch Specifications: 20 amp @ 125, 250 or 480 VAC — 10 amp @ 125 VAC "L" — 1 hp @ 125 VAC, 2 hp @ 250 VAC — 1/2 amp @ 125 VDC, 1/4 amp @ 250 VDC
- Enclosures: 27-1 and 27-2 — NEMA 3 and 4, dust and weathertight — 27-1X and 27-2X — NEMA 7, class I groups C & D and NEMA 9 class II groups E, F, and G. Explosion Proof.

NOTE: Switches may be wired for single throw operation, either normally open or normally closed as required.

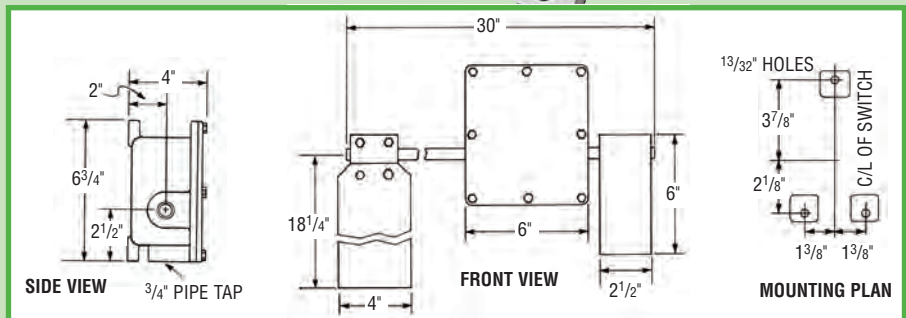
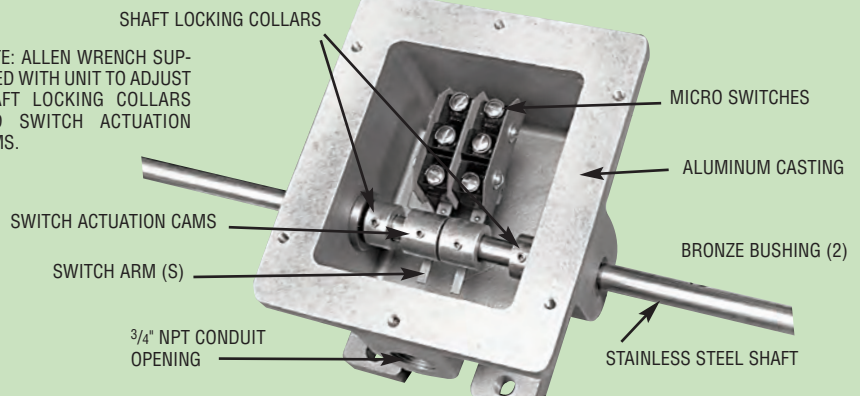

### INSTALLATION INSTRUCTIONS:

1. A cam on the shaft actuates the switch. Loosening the cam (or cams on the two switch unit) and the shaft locking collars permits the shaft to be moved laterally in the casting. The paddle sensor and counterweight can be positioned anywhere on the shaft. Use the 3/32" dia allen wrench furnished.
2. Housing can be mounted in any position. Counterweight permits paddle operation in any position from vertical to horizontal.
3. After mounting the unit the cover should be removed to adjust the cam on the shaft to give switch actuation at the desired point. Both the paddle and
4. The paddle or counterweight may have to be loosened, rotated, and retightened on the shaft to achieve proper actuation.

the counterweight may be easily field altered to suit application.